

## Warranty, Service & Repair

To register your product with the manufacturer, fill out the enclosed warranty card and return it immediately to:

Flowline Inc.  
10500 Humbolt Street  
Los Alamitos, CA 90720.

If for some reason your product must be returned for factory service, contact Flowline Inc. to receive a Material Return Authorization number (MRA) first, providing the following information:

1. Part Number, Serial Number
2. Name and telephone number of someone who can answer technical questions related to the product and its application.
3. Return Shipping Address
4. Brief Description of the Symptom
5. Brief Description of the Application

Once you have received a Material Return Authorization number, ship the product prepaid in its original packing to:

Flowline Factory Service  
MRA \_\_\_\_\_  
10500 Humbolt Street  
Los Alamitos, CA 90720

To avoid delays in processing your repair, write the MRA on the shipping label. Please include the information about the malfunction with your product. This information enables our service technicians to process your repair order as quickly as possible.

# FLOWLINE®

## Ricochet™ Alphasonic Level Transmitter Model LA15/20 Owner's Manual



Version 2.0A

© 2005 FLOWLINE Inc.

All rights reserved.

Manual # LA900003 LA15 0509 M2\_0

## WARRANTY

Flowline warrants to the original purchaser of its products that such products will be free from defects in material and workmanship under normal use and service for a period which is equal to the shorter of one year from the date of purchase of such products or two years from the date of manufacture of such products.

This warranty covers only those components of the products which are non-moving and not subject to normal wear. Moreover, products which are modified or altered, and electrical cables which are cut to length during installation are not covered by this warranty.

Flowline's obligation under this warranty is solely and exclusively limited to the repair or replacement, at Flowline's option, of the products (or components thereof) which Flowline's examination proves to its satisfaction to be defective. FLOWLINE SHALL HAVE NO OBLIGATION FOR CONSEQUENTIAL DAMAGES TO PERSONAL OR REAL PROPERTY, OR FOR INJURY TO ANY PERSON.

This warranty does not apply to products which have been subject to electrical or chemical damage due to improper use, accident, negligence, abuse or misuse. Abuse shall be assumed when indicated by electrical damage to relays, reed switches or other components. The warranty does not apply to products which are damaged during shipment back to Flowline's factory or designated service center or are returned without the original casing on the products. Moreover, this warranty becomes immediately null and void if anyone other than service personnel authorized by Flowline attempts to repair the defective products.

Products which are thought to be defective must be shipped prepaid and insured to Flowline's factory or a designated service center (the identity and address of which will be provided upon request) within 30 days of the discovery of the defect. Such defective products must be accompanied by proof of the date of purchase.

Flowline further reserves the right to unilaterally waive this warranty and to dispose of any product returned to Flowline where:

- a. There is evidence of a potentially hazardous material present with product.
- b. The product has remained unclaimed at Flowline for longer than 30 days after dutifully requesting disposition of the product.

THERE ARE NO WARRANTIES WHICH EXTEND BEYOND THE DESCRIPTION ON THE FACE OF THIS WARRANTY. This warranty and the obligations and liabilities of Flowline under it are exclusive and instead of, and the original purchaser hereby waives, all other remedies, warranties, guarantees or liabilities, express or implied. EXCLUDED FROM THIS WARRANTY IS THE IMPLIED WARRANTY OF FITNESS OF THE PRODUCTS FOR A PARTICULAR PURPOSE OR USE AND THE IMPLIED WARRANTY OF MERCHANTABILITY OF THE PRODUCTS.

This warranty may not be extended, altered or varied except by a written instrument signed by a duly-authorized officer of Flowline, Inc.

# SPECIFICATIONS

## Step One

- Range: LA15: 3.6" to 6' (9 cm to 1.8 m)  
LA20: 6" to 12' (15.2 cm to 3.6 m)
- Accuracy: ± .25% of span (air)
- Resolution: 0.125" (3 mm)
- Beam width: 8° conical
- Dead band: LA15: 3.6" (9 cm)  
LA20: 6" (15 cm)
- LED indication: Power and fail-safety
- Supply voltage: 12 - 36 VDC
- Loop resistance: 600 Ohms @ 24 VDC
- Signal output: 4-20 mA
- Fail-safety: Reverts to 22 mA during echo-loss
- Process Temp.: F: -40° to 140°  
C: -40° to 60°
- Temp. compensation: Automatic
- Electronics temp.: F: -4° to 140°  
C: -20° to 60°
- Pressure rating: 30 psi (2 bar) @ 25 °C., derated @ 1.667 psi (0.113 bar) per °C. above 25 °C.
- Enclosure rating: NEMA 4X (IP65)
- Enclosure material: PP, U.L. 94VO
- Transducer materials: PVDF
- Mounting threads: LA15: 3/4" NPT (3/4" G)  
LA20: 2" NPT (2" G)
- Mounting gasket: Viton (G version only)
- Conduit connection: 1/2" NPT
- Classification: General purpose
- CE compliance: EN 50082-2 immunity  
EN 55011 emission

### Dimensions:

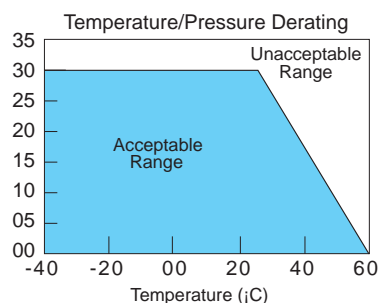
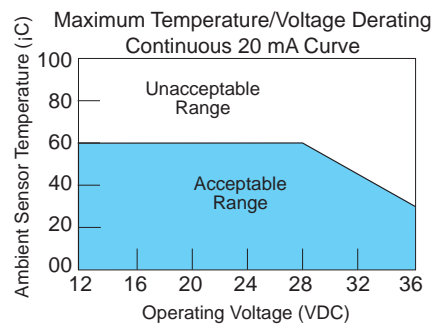
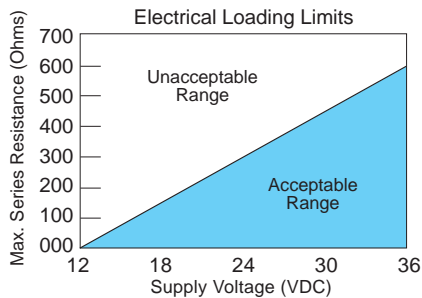
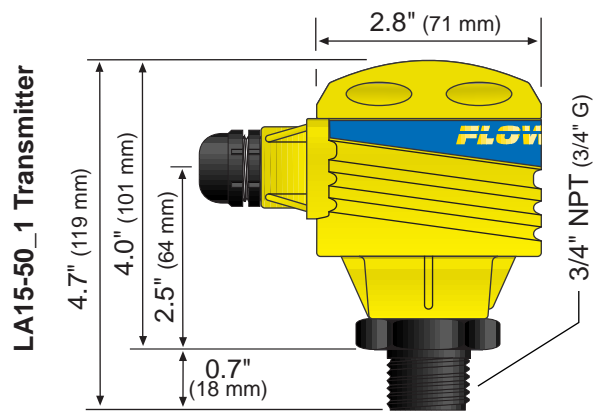
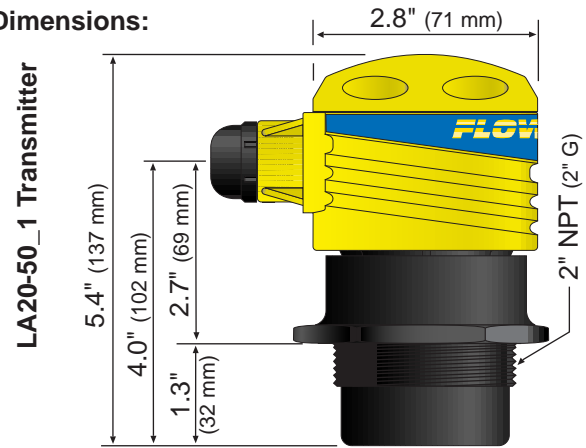

### Beam Cone Radius:

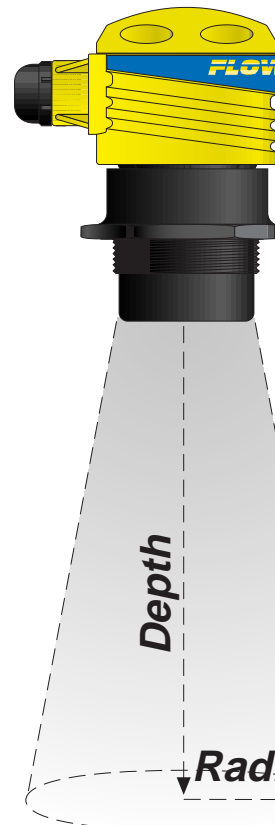

Depth Feet	Radius Inches	Radius cm
1	1.2	3.1
2	2.1	5.2
3	2.9	7.3
4	3.7	9.5
5	4.9	11.6
6	5.4	13.7
7	6.2	15.9
8	7.1	18.0
9	7.9	20.1
10	8.8	22.3
11	9.6	24.4
12	10.4	26.5

## SAFETY PRECAUTIONS

### Step Two

#### ⚠ About this Manual:

PLEASE READ THE ENTIRE MANUAL PRIOR TO INSTALLING OR USING THIS PRODUCT. This manual includes information on the Ricochet™ Alphasonic Level Transmitter from FLOWLINE: LA15-50\_1 and LA20-50\_1. Please refer to the part number located on the sensor label to verify the exact model which you have purchased.

#### ⚠ User's Responsibility for Safety:

FLOWLINE manufactures a wide range of liquid level sensors and technologies. While each of these sensors is designed to operate in a wide variety of applications, it is the user's responsibility to select a sensor model that is appropriate for the application, install it properly, perform tests of the installed system, and maintain all components. The failure to do so could result in property damage or serious injury.

#### ⚠ Proper Installation and Handling:

Because this is an electrically operated device, only properly-trained staff should install and/or repair this product. Use a proper sealant with all installations. Note: *Always install the Viton gasket with the LA\_\_-5061. The G threaded version of the Ricochet will not seal unless the gasket is installed properly.* Never overtighten the transmitter within the fitting. Always check for leaks prior to system start-up.

#### ⚠ Wiring and Electrical:

A supply voltage of 12-36 VDC is used to power the LA15/20 transmitter. The sensor systems should never exceed a maximum of 36 volts DC. Electrical wiring of the sensor should be performed in accordance with all applicable national, state, and local codes.

#### ⚠ Material Compatibility:

The Ricochet™ enclosure is made of Polypropylene (PP). The transducer is made of Polyvinylidene Fluoride (PVDF). Make sure that the model which you have selected is chemically compatible with the application liquids it will contact.

#### ⚠ Enclosure:

While the transmitter housing is liquid-resistant when installed properly, it is not designed to be immersed. It should be mounted in such a way that the enclosure and diaphragm do not come into contact with fluid.

#### ⚠ Make a Fail-Safe System:

Design a fail-safe system that accommodates the possibility of transmitter or power failure. In critical applications, FLOWLINE recommends the use of redundant backup systems and alarms in addition to the primary system.

#### ⚠ Flammable, Explosive and Hazardous Applications:

The LA15/20 transmitter systems should not be used within flammable or explosive applications.

#### ⚠ Warning ⚠

Always install the Viton gasket with all versions of the LA\_\_-5061. The G threaded version of the Ricochet will not seal unless the gasket is installed properly.

## WIRING

### Step Three

#### Wiring to Terminal:

The Ricochet™ arrives from the factory pre-calibrated and pre-assembled. Use the following instructions below for wiring to the LA15/20.

1. First, remove the cap of the transmitter:

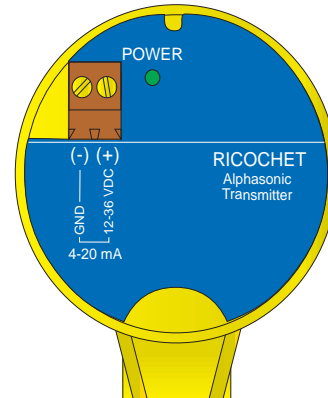

2. Look for the terminal block with two terminals.
3. Remove the terminal block to wire the LA20. The terminal to the right is positive and the terminal to the left is negative.
4. When finished attaching the wires, assemble the LA20 using steps 1 - 3 in reverse.

## WIRING

### Step Four

Follow the instructions in Step 3 for wiring to the Ricochet™.

#### 1. Wiring to a FLOWLINE Continuous Controller (LC52):

Connect the (+) terminal to the positive 24 VDC, 25 mA terminal on the LC52 controller. Connect the (-) terminal to the GND terminal on the LC52 continuous controller (See illustration below). Check LC52 instruction manual for setting the LC52 for loop powered operation.

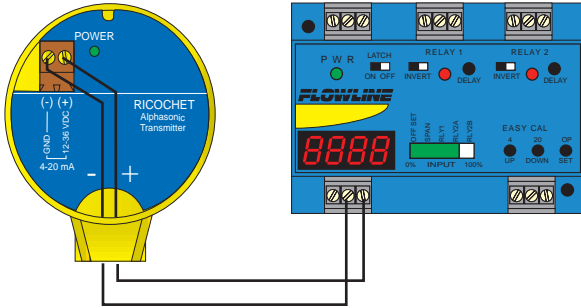

#### 2. Wiring to a Two-Wire Loop Powered Indicator:

The LA20 requires 12-36 VDC power and an indicator which receives a 4-20 mA current input. Connect the (+) terminal of the LA20 transmitter to the positive VDC terminal on the power supply. Connect the (-) terminal on the LA20 to the (+) terminal on the loop indicator. Connect the (-) of the loop indicator to the (-) of the power supply (See illustration below).

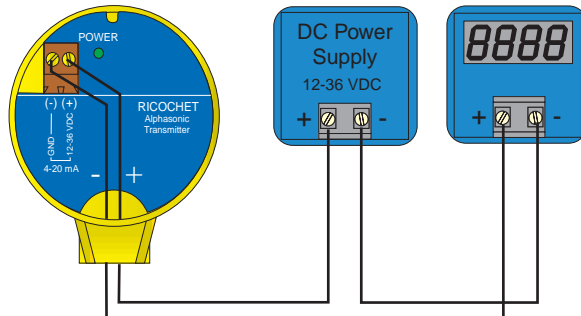

#### 3. Wiring to a Typical PLC:

The LA20 requires a PLC which provides a 12-36 VDC excitation and receives a 4-20 mA current input. Connect the (+) terminal of the LA20 transmitter to the positive VDC power terminal. Connect the (-) terminal on the LA20 to the (+) channel on the PLC. Connect the (-) of the PLC to the (-) of the power terminal (See illustration below).

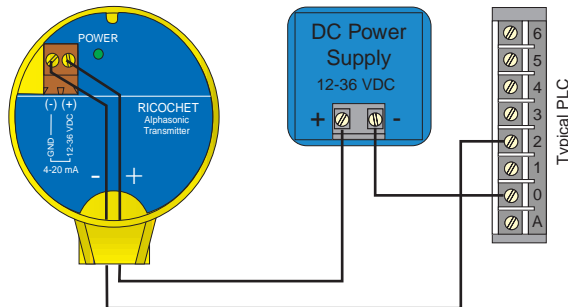

## INSTALLATION

### Step Five

FLOWLINE's LA15/20 transmitter may be installed through the top wall of a tank. Installation requires a 3/4" or 2" NPT fitting or blind flange.

1. Install the appropriate fitting in the top wall of the tank. Prior to installation, make sure that the fitting has been installed properly and checked for leaks. Use a proper sealant at the time of installation to ensure a liquid-tight seal. Secondly, make sure that the fittings threads are not damaged or worn.
2. Insert the Transmitter into the fitting and tighten to hand tight.
3. Always check for leaks prior to system start-up. To ensure proper installation, a complete leak test and simulation of actual process conditions should be preformed.

#### Fitting Installation

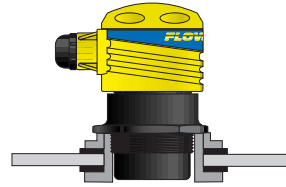

#### Flange Installation

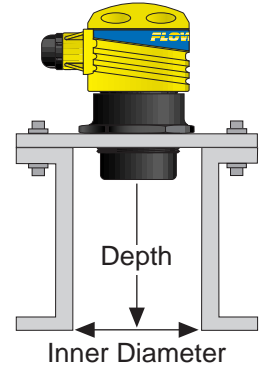

#### Flange Chart

Flange Inner Diameter Inch (cm)	Flange Depth Inch (cm)
3 (7.6)	3 (7.6)
4 (10.2)	7 (17.8)
5 (12.7)	11 (27.9)
6 (15.2)	15 (38.1)
7 (17.8)	19 (48.3)
8 (20.3)	26 (66.0)

Observe the Flange Chart to the left to determine the maximum depth for a flange installation.

#### Warning

Do not install the Ricochet™ in pressurized applications above 30 psi.

Always install the Viton gasket with all versions of the LA\_\_-5061. The G threaded version of the Ricochet will not seal unless the gasket is installed properly and checked for leaks.

Use a proper sealant at the time of installation to ensure a liquid-tight seal. Secondly, make sure that the fittings threads are not damaged or worn.

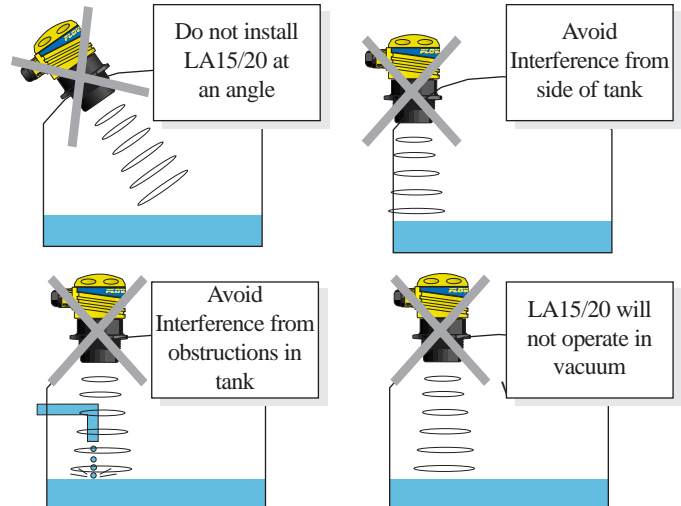

## CALIBRATION

### Step Six

The Ricochet™ is factory calibrated with a fixed measurement span of 12 feet. The 4 mA position is located 144" from the transducer face of the LA20. The 20 mA position is located 6 inches from the transducer face. Refer to the current to distance and distance to current conversion charts in step seven for reading the current output.

1. Connect a multimeter in series to read the current output.
2. Verify that as the distance from the liquid to the LA20 increases, the current signal decreases.
3. Verify that as the distance from the liquid to the LA20 decreases, the current signal increases.

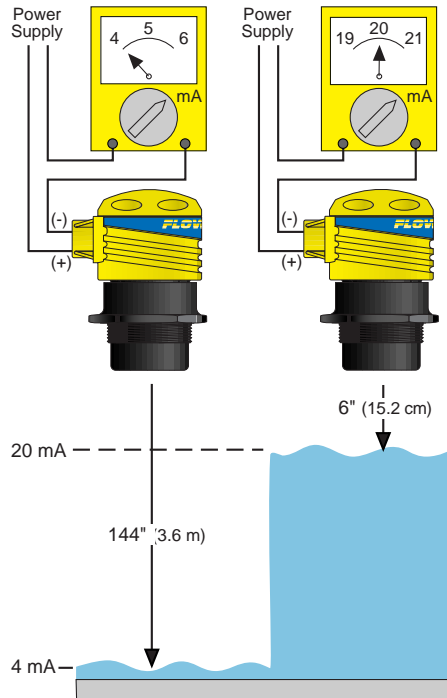

### LED Indication

The Ricochet™ features a single LED indicator which is used for power and fail-safe indication. During normal operation, the LED will be ON continuously to indicate that the transmitter has power and a strong echo signal return strength.

Should the LED begin to FLASH, it indicates that the transmitter has no signal return strength and the device has gone into a fail-safe condition. During the fail-safe condition, the current will increase up to 22 mA and hold until the acoustic signal is re-acquired. Once re-acquired, the LED will turn back ON continuously and the current will indicate the appropriate measured value.

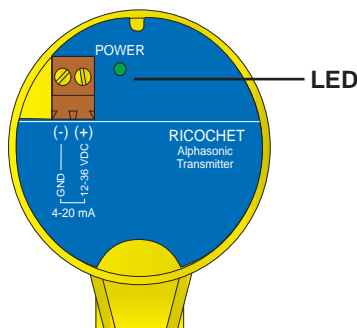

## CALIBRATION

### Step Seven

#### LA15 Series Current to Distance Chart (Nominal)

Current (mA)	Distance (inches)	Current (mA)	Distance (inches)	Current (mA)	Distance (inches)
20	03.6	14	29.2	08	54.9
19	07.9	13	33.5	07	59.2
18	12.1	12	37.8	06	63.5
17	16.4	11	42.1	05	67.7
16	20.7	10	46.3	04	72.0
15	25.0	09	50.6		

Current (mA)	Distance (meters)	Current (mA)	Distance (meters)	Current (mA)	Distance (meters)
20	0.09	14	0.74	08	1.39
19	0.20	13	0.85	07	1.50
18	0.31	12	0.96	06	1.61
17	0.42	11	1.07	05	1.72
16	0.53	10	1.18	04	1.83
15	0.64	09	1.29		

#### LA15 Series Distance to Current Chart (Nominal)

Distance (inches)	Current (mA)	Distance (inches)	Current (mA)	Distance (inches)	Current (mA)
3.6	20.0	30	13.8	60	06.8
06	19.4	36	12.4	66	05.4
12	18.0	42	11.0	72	04.0
18	16.6	48	09.6		
24	15.2	54	08.2		

Distance (meters)	Current (mA)	Distance (meters)	Current (mA)	Distance (meters)	Current (mA)
0.09	20.0	0.80	13.5	1.60	06.1
0.20	19.0	1.00	11.6	1.80	04.3
0.40	17.2	1.20	09.8	1.83	04.0
0.60	15.3	1.40	07.9		

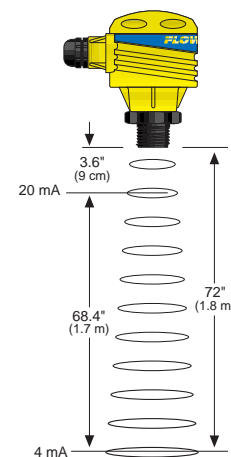

## CALIBRATION

## MAINTENANCE

### Step Eight

#### LA20 Current to Distance Chart (Nominal)

Current (mA)	Distance (inches)	Current (mA)	Distance (inches)	Current (mA)	Distance (inches)
20	06.0	14	57.8	08	109.5
19	14.6	13	66.4	07	118.1
18	23.3	12	75.0	06	126.8
17	31.9	11	83.6	05	135.4
16	40.5	10	92.3	04	144.0
15	49.1	09	100.9		

Current (mA)	Distance (meters)	Current (mA)	Distance (meters)	Current (mA)	Distance (meters)
20	0.15	14	1.47	08	2.78
19	0.37	13	1.69	07	3.00
18	0.59	12	1.91	06	3.22
17	0.81	11	2.12	05	3.44
16	1.03	10	2.34	04	3.66
15	1.25	09	2.56		

#### LA20 Distance to Current Chart (Nominal)

Distance (inches)	Current (mA)	Distance (inches)	Current (mA)	Distance (inches)	Current (mA)
06	20.0	54	14.4	102	08.9
12	19.3	60	13.7	108	08.2
18	18.6	66	13.0	114	07.5
24	17.9	72	12.3	120	06.8
30	17.2	78	11.7	126	06.1
36	16.5	84	11.0	132	05.4
42	15.8	90	10.3	138	04.7
48	15.1	96	09.6	144	04.0

Distance (meters)	Current (mA)	Distance (meters)	Current (mA)	Distance (meters)	Current (mA)
0.15	20.0	1.40	14.3	2.80	07.9
0.20	19.8	1.60	13.4	3.00	07.0
0.40	18.9	1.80	12.5	3.20	06.1
0.60	18.0	2.00	11.6	3.40	05.2
0.80	17.0	2.20	10.7	3.60	04.3
1.00	16.1	2.40	09.7	3.66	04.0
1.20	15.2	2.60	08.8		

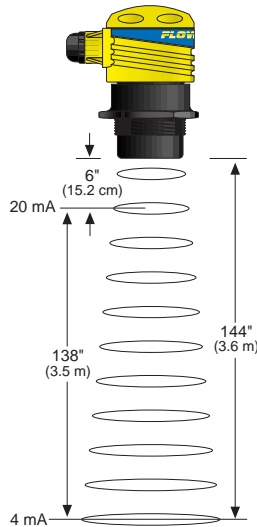

### Step Nine

#### General:

The LA15/20 series level transmitter itself requires no periodic maintenance except cleaning as required. It is the responsibility of the user to determine the appropriate maintenance schedule, based on the specific characteristics of the application liquids.

#### Cleaning Procedure:

1. Power: Make Sure that all power to the transmitter, controller and/or power supply is completely disconnected.
2. Sensor Removal: In all through-wall installations, make sure that the tank is drained well below the sensor prior to removal. Carefully, remove the sensor from the installation.
3. Cleaning the Sensor: Use a soft bristle brush and mild detergent, carefully wash the transducer of the LA15/20. Do not use harsh abrasives such as steel wool or sandpaper, which might damage the transmitter's surface. Do not use incompatible solvents which may damage the PVDF transducer or the transmitters PP body.
4. Sensor Installation: Follow the appropriate steps of installation as outlined in the installation section of this manual.